

Product Data Sheet



KP-DK-ATOMGEN2-V2

BaiCells Atom OD04-14 and OD06 Outdoor UE Radio Mount with Standard Reflector Dish Antenna for 2GHz/3GHz GEN 2 and Cat 6 Radios – 4 Pack Box

- Rugged, high-grade aluminium bracket

Electrical Specification

Radio Model Number		EG7035L-M1	EG7035L-M2	EG7010C-M19	EG7010C-M11
		2.4GHz	3.5GHz	2.4GHz	3.5GHz
Frequency Band	MHz	2300-2690	3500-3800	2300-2690	3500-3800
Reflector Gain	dBi	19±0.5	22±0.5	18.0±0.5	20±0.5
Reflector Gain Over Radio	dBi	8±0.5	8±0.5	10±0.5	9±0.5
Polarization		Slant ±45° (D)	Slant ±45° (D)	Slant ±45° (D)	Slant ±45° (D)
Horizontal HPBW	Degrees	12	10	19	17
Vertical HPBW	Degrees	17	15	17	15
Front-to-Back Ratio	dB	25	25	25	25

Mechanical Specifications

Electrical Grounding	Reflector grounded to mounting bracket
Surface Finish	Matt Powder Coat
Max. Wind Speed	160km/h 100mph
Temperature Range	-40° to +60°C -40° to +140° F
Mounting Type	Pipe Mount
Mounting pole diameter	25 mm – 100 mm 1¼ in – 4 in

Reflector Dimensions

Length	584 mm 23 in
Width	510 mm 20 in
Height	635 mm 25 in
Net Weight, with brackets	5.4 kg 12 lb

FCC Information

Antenna Data

16) Transmitter Antenna Manufacturer:		17) Transmitter Antenna Model Number:	
18) Transmitter Antenna Gain (dBi):	19) Transmitter Antenna Beamwidth (Degrees):	20) Transmitter Antenna Center Line (meters-AGL):	
21) Transmitter Antenna Azimuth (Degrees):		22) Transmitter Antenna Elevation Angle (Degrees):	
23) Polarization: D			
24) Receiver Antenna Manufacturer:		25) Receiver Antenna Model Number:	
KP Performance Antennas		KP-DK-ATOMGEN2-V2	
26) Receiver Antenna Gain (dBi):		27) Receiver Antenna Beamwidth (Degrees):	
28) Receiver Antenna Center Line (meters-AGL):	29) Receiver Antenna Azimuth (Degrees):	30) Receiver Antenna Elevation Angle (Degrees):	

26) Receiver Antenna Gain (dBi): Enter reflector gain of your radio model number.

27) Receiver Antenna Beamwidth (Degrees): Enter horizontal HPBW of your radio model.

Alignment Instructions

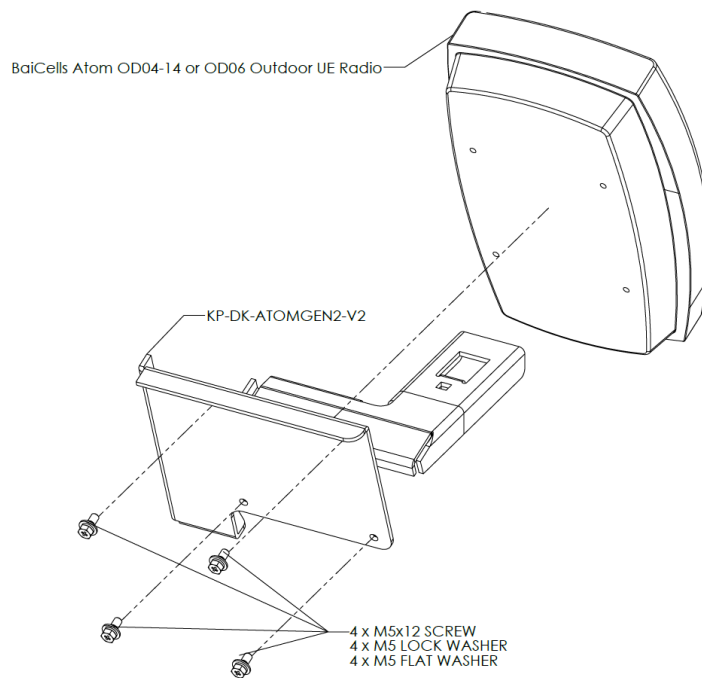

1. Assemble the reflector according to its installation instructions.
2. Attach the radio to the mount using the radio's four screws and attach the mount to the reflector.
3. Standing behind the antenna, point the reflector towards the AP antenna. Set the elevation angle to the required angle using the reflector's tilt markings as guidance. Determine this angle by eye, with RF link planning software, or an external alignment tool.
4. Set the azimuth angle by rotating the reflector. Determine this angle by eye, with RF link planning software and a compass, or an external alignment tool.
5. While monitoring the receive signal strength, fine tune the azimuth and elevation angles to maximize the signal strength.

Additional instructions for OD06 Cat 6 Radio:

6. Fine tune the elevation angle to maximize the signal strength of two of the chains simultaneously.
7. Fine tune the reflector's azimuth angle to maximize the signal strength of all four chains simultaneously.